

74HC244; 74HCT244

Octal buffer/line driver; 3-state

Product data sheet

1. General description

The 74HC244; 74HCT244 is a high-speed Si-gate CMOS device and is pin compatible with Low-power Schottky TTL (LSTTL).

The 74HC244; 74HCT244 has octal non-inverting buffer/line drivers with 3-state outputs. The 3-state outputs are controlled by the output enable inputs $\overline{1OE}$ and $\overline{2OE}$. A HIGH on \overline{nOE} causes the outputs to assume a high-impedance OFF-state. The 74HC244; 74HCT244 is identical to the 74HC240; 74HCT240 but has non-inverting outputs.

2. Features

- Octal bus interface
- Non-inverting 3-state outputs
- Complies with JEDEC standard no. 7A
- ESD protection:
 - ◆ HBM EIA/JESD22-A114-C exceeds 2000 V
 - ◆ MM EIA/JESD22-A115-A exceeds 200 V
- Multiple package options
- Specified from $-40\text{ }^{\circ}\text{C}$ to $+85\text{ }^{\circ}\text{C}$ and from $-40\text{ }^{\circ}\text{C}$ to $+125\text{ }^{\circ}\text{C}$

3. Quick reference data

Table 1: Quick reference data

$GND = 0\text{ V}$; $T_{amb} = 25\text{ }^{\circ}\text{C}$; $t_r = t_f = 6\text{ ns}$

Symbol	Parameter	Conditions	Min	Typ	Max	Unit
74HC244						
t_{PHL} , t_{PLH}	propagation delay nAn to nYn	$V_{CC} = 5\text{ V}$; $C_L = 15\text{ pF}$	-	9	-	ns
C_i	input capacitance		-	3.5	-	pF
C_{PD}	power dissipation capacitance	per buffer; $V_I = GND$ to V_{CC}	[1]	-	35	pF
74HCT244						
t_{PHL} , t_{PLH}	propagation delay nAn to nYn	$V_{CC} = 5\text{ V}$; $C_L = 15\text{ pF}$	-	11	-	ns
C_i	input capacitance		-	3.5	-	pF
C_{PD}	power dissipation capacitance	per buffer; $V_I = GND$ to $(V_{CC} - 1.5\text{ V})$	[1]	-	35	pF

[1] C_{PD} is used to determine the dynamic power dissipation (P_D in μW):

$$P_D = C_{PD} \times V_{CC}^2 \times f_i \times N + \sum(C_L \times V_{CC}^2 \times f_o) \text{ where:}$$

PHILIPS

f_i = input frequency in MHz;
 f_o = output frequency in MHz;
 C_L = output load capacitance in pF;
 V_{CC} = supply voltage in V;
 N = number of inputs switching;
 $\Sigma(C_L \times V_{CC}^2 \times f_o)$ = sum of outputs.

4. Ordering information

Table 2: Ordering information

Type number	Package			
	Temperature range	Name	Description	Version
74HC244				
74HC244N	−40 °C to +125 °C	DIP20	plastic dual in-line package; 20 leads (300 mil)	SOT146-1
74HC244D	−40 °C to +125 °C	SO20	plastic small outline package; 20 leads; body width 7.5 mm	SOT163-1
74HC244DB	−40 °C to +125 °C	SSOP20	plastic shrink small outline package; 20 leads; body width 5.3 mm	SOT339-1
74HC244PW	−40 °C to +125 °C	TSSOP20	plastic thin shrink small outline package; 20 leads; body width 4.4 mm	SOT360-1
74HC244BQ	−40 °C to +125 °C	DHVQFN20	plastic dual in-line compatible thermal enhanced very thin quad flat package; no leads; 20 terminals; body 2.5 × 4.5 × 0.85 mm	SOT764-1
74HCT244				
74HCT244N	−40 °C to +125 °C	DIP20	plastic dual in-line package; 20 leads (300 mil)	SOT146-1
74HCT244D	−40 °C to +125 °C	SO20	plastic small outline package; 20 leads; body width 7.5 mm	SOT163-1
74HCT244DB	−40 °C to +125 °C	SSOP20	plastic shrink small outline package; 20 leads; body width 5.3 mm	SOT339-1
74HCT244PW	−40 °C to +125 °C	TSSOP20	plastic thin shrink small outline package; 20 leads; body width 4.4 mm	SOT360-1
74HCT244BQ	−40 °C to +125 °C	DHVQFN20	plastic dual in-line compatible thermal enhanced very thin quad flat package; no leads; 20 terminals; body 2.5 × 4.5 × 0.85 mm	SOT764-1

Table 3: Pin description ...continued

Symbol	Pin	Description
2A1	15	2 data input 1
1Y1	16	1 bus output 1
2A0	17	2 data input 0
1Y0	18	1 bus output 0
$\overline{2OE}$	19	2 output enable input (active LOW)
V _{CC}	20	supply voltage

7. Functional description

7.1 Function table

Table 4: Function table [1]

Control	Input	Output
\overline{nOE}	nAn	nYn
L	L	L
	H	H
H	X	Z

- [1] H = HIGH voltage level;
 L = LOW voltage level;
 X = don't care;
 Z = high-impedance OFF-state.

8. Limiting values

Table 5: Limiting values

In accordance with the Absolute Maximum Rating System (IEC 60134). Voltages are referenced to GND (ground = 0 V).

Symbol	Parameter	Conditions	Min	Max	Unit
V _{CC}	supply voltage		-0.5	+7	V
I _{IK}	input clamping current	$V_I < -0.5 \text{ V}$ or $V_I > V_{CC} + 0.5 \text{ V}$	-	±20	mA
I _{OK}	output clamping current	$V_O < -0.5 \text{ V}$ or $V_O > V_{CC} + 0.5 \text{ V}$	-	±20	mA
I _O	output current	$V_O = -0.5 \text{ V}$ to $(V_{CC} + 0.5 \text{ V})$	-	±35	mA
I _{CC}	quiescent supply current		-	70	mA
I _{GND}	ground current		-	-70	mA
T _{stg}	storage temperature		-65	+150	°C
P _{tot}	total power dissipation				
	DIP20 package		[1] -	750	mW
	SO20 package		[2] -	500	mW
	SSOP20 package		[3] -	500	mW
	TSSOP20 package		[3] -	500	mW
	DHVQFN20 package		[4] -	500	mW

- [1] For DIP20 package: P_{tot} derates linearly with 12 mW/K above 70 °C.
 [2] For SO20 package: P_{tot} derates linearly with 8 mW/K above 70 °C.
 [3] For SSOP20 and TSSOP20 packages: P_{tot} derates linearly with 5.5 mW/K above 60 °C
 [4] For DHVQFN20 packages: P_{tot} derates linearly with 4.5 mW/K above 60 °C.

9. Recommended operating conditions

Table 6: Recommended operating conditions

Symbol	Parameter	Conditions	Min	Typ	Max	Unit
74HC244						
V_{CC}	supply voltage		2.0	5.0	6.0	V
V_I	input voltage		0	-	V_{CC}	V
V_O	output voltage		0	-	V_{CC}	V
T_{amb}	ambient temperature		-40	25	+125	°C
t_r, t_f	input rise and fall time	$V_{CC} = 2.0$ V	-	-	1000	ns
		$V_{CC} = 4.5$ V	-	6.0	500	ns
		$V_{CC} = 6.0$ V	-	-	400	ns
74HCT244						
V_{CC}	supply voltage		4.5	5.0	5.5	V
V_I	input voltage		0	-	V_{CC}	V
V_O	output voltage		0	-	V_{CC}	V
T_{amb}	ambient temperature		-40	25	+125	°C
t_r, t_f	input rise and fall time	$V_{CC} = 4.5$ V	-	6.0	500	ns

10. Static characteristics

Table 7: Static characteristics 74HC244

At recommended operating conditions; voltages are referenced to GND (ground = 0V).

Symbol	Parameter	Conditions	Min	Typ	Max	Unit
$T_{amb} = 25$ °C						
V_{IH}	HIGH-state input voltage	$V_{CC} = 2.0$ V	1.5	1.2	-	V
		$V_{CC} = 4.5$ V	3.15	2.4	-	V
		$V_{CC} = 6.0$ V	4.2	3.2	-	V
V_{IL}	LOW-state input voltage	$V_{CC} = 2.0$ V	-	0.8	0.5	V
		$V_{CC} = 4.5$ V	-	2.1	1.35	V
		$V_{CC} = 6.0$ V	-	2.8	1.8	V
V_{OH}	HIGH-state output voltage	$V_I = V_{IH}$ or V_{IL}	-	-	-	
		$I_O = -20$ μ A; $V_{CC} = 2.0$ V	1.9	2.0	-	V
		$I_O = -20$ μ A; $V_{CC} = 4.5$ V	4.4	4.5	-	V
		$I_O = -20$ μ A; $V_{CC} = 6.0$ V	5.9	6.0	-	V
		$I_O = -6.0$ mA; $V_{CC} = 4.5$ V	3.98	4.32	-	V
		$I_O = -7.8$ mA; $V_{CC} = 6$ V	5.48	5.81	-	V

Table 7: Static characteristics 74HC244 ...continued

At recommended operating conditions; voltages are referenced to GND (ground = 0V).

Symbol	Parameter	Conditions	Min	Typ	Max	Unit
V _{OL}	LOW-state output voltage	V _I = V _{IH} or V _{IL}				
		I _O = 20 μA; V _{CC} = 2.0 V	-	0	0.1	V
		I _O = 20 μA; V _{CC} = 4.5 V	-	0	0.1	V
		I _O = 20 μA; V _{CC} = 6.0 V	-	0	0.1	V
		I _O = 6.0 mA; V _{CC} = 4.5 V	-	0.15	0.26	V
		I _O = 7.8 mA; V _{CC} = 6 V	-	0.16	0.26	V
I _{LI}	input leakage current	V _I = V _{CC} or GND; V _{CC} = 6 V	-	-	±0.1	μA
I _{OZ}	OFF-state output current	V _I = V _{IH} or V _{IL} ; V _O = V _{CC} or GND	-	-	±0.5	μA
I _{CC}	quiescent supply current	V _I = V _{CC} or GND; I _O = 0 A; V _{CC} = 6.0 V	-	-	8.0	μA
C _i	input capacitance		-	3.5	-	pF
T_{amb} = -40 °C to +85 °C						
V _{IH}	HIGH-state input voltage	V _{CC} = 2.0 V	1.5	-	-	V
		V _{CC} = 4.5 V	3.15	-	-	V
		V _{CC} = 6.0 V	4.2	-	-	V
V _{IL}	LOW-state input voltage	V _{CC} = 2.0 V	-	-	0.5	V
		V _{CC} = 4.5 V	-	-	1.35	V
		V _{CC} = 6.0 V	-	-	1.8	V
V _{OH}	HIGH-state output voltage	V _I = V _{IH} or V _{IL}				
		I _O = -20 μA; V _{CC} = 2.0 V	1.9	-	-	V
		I _O = -20 μA; V _{CC} = 4.5 V	4.4	-	-	V
		I _O = -20 μA; V _{CC} = 6.0 V	5.9	-	-	V
		I _O = -6.0 mA; V _{CC} = 4.5 V	3.84	-	-	V
		I _O = -7.8 mA; V _{CC} = 6 V	5.34	-	-	V
V _{OL}	LOW-state output voltage	V _I = V _{IH} or V _{IL}				
		I _O = 20 μA; V _{CC} = 2.0 V	-	-	0.1	V
		I _O = 20 μA; V _{CC} = 4.5 V	-	-	0.1	V
		I _O = 20 μA; V _{CC} = 6.0 V	-	-	0.1	V
		I _O = 6.0 mA; V _{CC} = 4.5 V	-	-	0.33	V
		I _O = 7.8 mA; V _{CC} = 6 V	-	-	0.33	V
I _{LI}	input leakage current	V _I = V _{CC} or GND; V _{CC} = 6 V	-	-	±1.0	μA
I _{OZ}	OFF-state output current	V _I = V _{IH} or V _{IL} ; V _O = V _{CC} or GND	-	-	±5.0	μA
I _{CC}	quiescent supply current	V _I = V _{CC} or GND; I _O = 0 A; V _{CC} = 6.0 V	-	-	80	μA

Table 7: Static characteristics 74HC244 ...continued

At recommended operating conditions; voltages are referenced to GND (ground = 0V).

Symbol	Parameter	Conditions	Min	Typ	Max	Unit
T_{amb} = -40 °C to +125 °C						
V _{IH}	HIGH-state input voltage	V _{CC} = 2.0 V	1.5	-	-	V
		V _{CC} = 4.5 V	3.15	-	-	V
		V _{CC} = 6.0 V	4.2	-	-	V
V _{IL}	LOW-state input voltage	V _{CC} = 2.0 V	-	-	0.5	V
		V _{CC} = 4.5 V	-	-	1.35	V
		V _{CC} = 6.0 V	-	-	1.8	V
V _{OH}	HIGH-state output voltage	V _I = V _{IH} or V _{IL}				
		I _O = -20 μA; V _{CC} = 2.0 V	1.9	-	-	V
		I _O = -20 μA; V _{CC} = 4.5 V	4.4	-	-	V
		I _O = -20 μA; V _{CC} = 6.0 V	5.9	-	-	V
		I _O = -6.0 mA; V _{CC} = 4.5 V	3.7	-	-	V
V _{OL}	LOW-state output voltage	V _I = V _{IH} or V _{IL}				
		I _O = 20 μA; V _{CC} = 2.0 V	-	-	0.1	V
		I _O = 20 μA; V _{CC} = 4.5 V	-	-	0.1	V
		I _O = 20 μA; V _{CC} = 6.0 V	-	-	0.1	V
		I _O = 6.0 mA; V _{CC} = 4.5 V	-	-	0.4	V
I _{LI}	input leakage current	I _O = 7.8 mA; V _{CC} = 6 V	-	-	0.4	V
		V _I = V _{CC} or GND; V _{CC} = 6 V	-	-	±1.0	μA
I _{OZ}	OFF-state output current	V _I = V _{IH} or V _{IL} ; V _O = V _{CC} or GND	-	-	±10.0	μA
I _{CC}	quiescent supply current	V _I = V _{CC} or GND; I _O = 0 A; V _{CC} = 6.0 V	-	-	160	μA

Table 8: Static characteristics 74HCT244

At recommended operating conditions; voltages are referenced to GND (ground = 0 V).

Symbol	Parameter	Conditions	Min	Typ	Max	Unit
T_{amb} = 25 °C						
V _{IH}	HIGH-state input voltage	V _{CC} = 4.5 V to 5.5 V	2.0	1.6	-	V
V _{IL}	LOW-state input voltage	V _{CC} = 4.5 V to 5.5 V	-	1.2	0.8	V
V _{OH}	HIGH-state output voltage	V _I = V _{IH} or V _{IL} ; V _{CC} = 4.5 V				
		I _O = -20 μA	4.4	4.5	-	V
		I _O = -6.0 mA	3.98	4.32	-	V
V _{OL}	LOW-state output voltage	V _I = V _{IH} or V _{IL} ; V _{CC} = 4.5 V				
		I _O = 20 μA	-	0	0.1	V
		I _O = 6.0 mA	-	0.16	0.26	V
I _{LI}	input leakage current	V _I = V _{CC} or GND; V _{CC} = 5.5 V	-	-	±0.1	μA
I _{OZ}	OFF-state output current	per input pin; V _I = V _{IH} or V _{IL} ; V _O = V _{CC} or GND; other pins at GND or V _{CC} ; I _O = 0 A; V _{CC} = 5.5 V	-	-	±0.5	μA
I _{CC}	quiescent supply current	V _I = V _{CC} or GND; I _O = 0 A; V _{CC} = 5.5 V	-	-	8.0	μA

Table 8: Static characteristics 74HCT244 ...continued

At recommended operating conditions; voltages are referenced to GND (ground = 0 V).

Symbol	Parameter	Conditions	Min	Typ	Max	Unit
ΔI_{CC}	additional quiescent supply current	per input pin; $V_I = V_{CC} - 2.1$ V; other inputs at V_{CC} or GND; $I_O = 0$ A; $V_{CC} = 4.5$ V to 5.5 V		70	252	μ A
C_i	input capacitance		-	3.5	-	pF
$T_{amb} = -40$ °C to $+85$ °C						
V_{IH}	HIGH-state input voltage	$V_{CC} = 4.5$ V to 5.5 V	2.0	-	-	V
V_{IL}	LOW-state input voltage	$V_{CC} = 4.5$ V to 5.5 V	-	-	0.8	V
V_{OH}	HIGH-state output voltage	$V_I = V_{IH}$ or V_{IL} ; $V_{CC} = 4.5$ V				
		$I_O = -20$ μ A	4.4	-	-	V
		$I_O = -6.0$ mA	3.84	-	-	V
V_{OL}	LOW-state output voltage	$V_I = V_{IH}$ or V_{IL} ; $V_{CC} = 4.5$ V				
		$I_O = 20$ μ A	-	-	0.1	V
		$I_O = 6.0$ mA	-	-	0.33	V
I_{LI}	input leakage current	$V_I = V_{CC}$ or GND; $V_{CC} = 5.5$ V	-	-	± 1.0	μ A
I_{OZ}	OFF-state output current	per input pin; $V_I = V_{IH}$ or V_{IL} ; $V_O = V_{CC}$ or GND; other pins at GND or V_{CC} ; $I_O = 0$ A; $V_{CC} = 5.5$ V			± 5.0	μ A
I_{CC}	quiescent supply current	$V_I = V_{CC}$ or GND; $I_O = 0$ A; $V_{CC} = 5.5$ V	-	-	80	μ A
ΔI_{CC}	additional quiescent supply current	per input pin; $V_I = V_{CC} - 2.1$ V; other inputs at V_{CC} or GND; $I_O = 0$ A; $V_{CC} = 4.5$ V to 5.5 V	-	-	315	μ A
$T_{amb} = -40$ °C to $+125$ °C						
V_{IH}	HIGH-state input voltage	$V_{CC} = 4.5$ V to 5.5 V	2.0	-	-	V
V_{IL}	LOW-state input voltage	$V_{CC} = 4.5$ V to 5.5 V	-	-	0.8	V
V_{OH}	HIGH-state output voltage	$V_I = V_{IH}$ or V_{IL} ; $V_{CC} = 4.5$ V				
		$I_O = -20$ μ A	4.4	-	-	V
		$I_O = -6.0$ mA	3.7	-	-	V
V_{OL}	LOW-state output voltage	$V_I = V_{IH}$ or V_{IL} ; $V_{CC} = 4.5$ V				
		$I_O = 20$ μ A	-	-	0.1	V
		$I_O = 6.0$ mA	-	-	0.4	V
I_{LI}	input leakage current	$V_I = V_{CC}$ or GND; $V_{CC} = 5.5$ V	-	-	± 1.0	μ A
I_{OZ}	OFF-state output current	per input pin; $V_I = V_{IH}$ or V_{IL} ; $V_O = V_{CC}$ or GND; other pins at GND or V_{CC} ; $I_O = 0$ A; $V_{CC} = 5.5$ V	-	-	± 10.0	μ A
I_{CC}	quiescent supply current	$V_I = V_{CC}$ or GND; $I_O = 0$ A; $V_{CC} = 5.5$ V	-	-	160	μ A
ΔI_{CC}	additional quiescent supply current	per input pin; $V_I = V_{CC} - 2.1$ V; other inputs at V_{CC} or GND; $I_O = 0$ A; $V_{CC} = 4.5$ V to 5.5 V	-	-	343	μ A

11. Dynamic characteristics

Table 9: Dynamic characteristics 74HC244

$GND = 0\text{ V}$; $t_r = t_f = 6\text{ ns}$; $C_L = 50\text{ pF}$ unless otherwise specified; for test circuit see [Figure 8](#).

Symbol	Parameter	Conditions	Min	Typ	Max	Unit
$T_{amb} = 25\text{ °C}$						
t_{PHL} , t_{PLH}	propagation delay nAn to nYn	see Figure 6				
		$V_{CC} = 2.0\text{ V}$	-	30	110	ns
		$V_{CC} = 4.5\text{ V}$	-	11	22	ns
		$V_{CC} = 5\text{ V}$; $C_L = 15\text{ pF}$	-	9	-	ns
		$V_{CC} = 6.0\text{ V}$	-	9	19	ns
t_{PZH} , t_{PZL}	3-state output enable time n \overline{OE} to nYn	see Figure 7				
		$V_{CC} = 2.0\text{ V}$	-	36	150	ns
		$V_{CC} = 4.5\text{ V}$	-	13	30	ns
		$V_{CC} = 6.0\text{ V}$	-	10	26	ns
t_{PHZ} , t_{PLZ}	3-state output disable time n \overline{OE} to nYn	see Figure 7				
		$V_{CC} = 2.0\text{ V}$	-	39	150	ns
		$V_{CC} = 4.5\text{ V}$	-	14	30	ns
		$V_{CC} = 6.0\text{ V}$	-	11	26	ns
t_{THL} , t_{TLH}	output transition time	see Figure 6				
		$V_{CC} = 2.0\text{ V}$	-	14	60	ns
		$V_{CC} = 4.5\text{ V}$	-	5	12	ns
		$V_{CC} = 6.0\text{ V}$	-	4	10	ns
C_{PD}	power dissipation capacitance	$V_I = GND$ to V_{CC}	[1] -	35	-	pF
$T_{amb} = -40\text{ °C to }+85\text{ °C}$						
t_{PHL} , t_{PLH}	propagation delay nAn to nYn	see Figure 6				
		$V_{CC} = 2.0\text{ V}$	-	-	145	ns
		$V_{CC} = 4.5\text{ V}$	-	-	28	ns
		$V_{CC} = 6.0\text{ V}$	-	-	24	ns
t_{PZH} , t_{PZL}	3-state output enable time n \overline{OE} to nYn	see Figure 7				
		$V_{CC} = 2.0\text{ V}$	-	-	190	ns
		$V_{CC} = 4.5\text{ V}$	-	-	38	ns
		$V_{CC} = 6.0\text{ V}$	-	-	33	ns
t_{PHZ} , t_{PLZ}	3-state output disable time n \overline{OE} to nYn	see Figure 7				
		$V_{CC} = 2.0\text{ V}$	-	-	190	ns
		$V_{CC} = 4.5\text{ V}$	-	-	38	ns
		$V_{CC} = 6.0\text{ V}$	-	-	33	ns
t_{THL} , t_{TLH}	output transition time	see Figure 6				
		$V_{CC} = 2.0\text{ V}$	-	-	75	ns
		$V_{CC} = 4.5\text{ V}$	-	-	15	ns
		$V_{CC} = 6.0\text{ V}$	-	-	13	ns

Table 9: Dynamic characteristics 74HC244 ...continued

$GND = 0\text{ V}$; $t_r = t_f = 6\text{ ns}$; $C_L = 50\text{ pF}$ unless otherwise specified; for test circuit see [Figure 8](#).

Symbol	Parameter	Conditions	Min	Typ	Max	Unit
$T_{\text{amb}} = -40\text{ °C to }+125\text{ °C}$						
t_{PHL} , t_{PLH}	propagation delay nAn to nYn	see Figure 6				
		$V_{\text{CC}} = 2.0\text{ V}$	-	-	165	ns
		$V_{\text{CC}} = 4.5\text{ V}$	-	-	33	ns
		$V_{\text{CC}} = 6.0\text{ V}$	-	-	28	ns
t_{PZH} , t_{PZL}	3-state output enable time n $\overline{\text{OE}}$ to nYn	see Figure 7				
		$V_{\text{CC}} = 2.0\text{ V}$	-	-	225	ns
		$V_{\text{CC}} = 4.5\text{ V}$	-	-	45	ns
		$V_{\text{CC}} = 6.0\text{ V}$	-	-	38	ns
t_{PHZ} , t_{PLZ}	3-state output disable time n $\overline{\text{OE}}$ to nYn	see Figure 7				
		$V_{\text{CC}} = 2.0\text{ V}$	-	-	225	ns
		$V_{\text{CC}} = 4.5\text{ V}$	-	-	45	ns
		$V_{\text{CC}} = 6.0\text{ V}$	-	-	38	ns
t_{THL} , t_{TLH}	output transition time	see Figure 6				
		$V_{\text{CC}} = 2.0\text{ V}$	-	-	90	ns
		$V_{\text{CC}} = 4.5\text{ V}$	-	-	18	ns
		$V_{\text{CC}} = 6.0\text{ V}$	-	-	15	ns

[1] C_{PD} is used to determine the dynamic power dissipation (P_{D} in μW):

$$P_{\text{D}} = C_{\text{PD}} \times V_{\text{CC}}^2 \times f_i \times N + \sum(C_L \times V_{\text{CC}}^2 \times f_o) \text{ where:}$$

f_i = input frequency in MHz;

f_o = output frequency in MHz;

C_L = output load capacitance in pF;

V_{CC} = supply voltage in V;

N = number of inputs switching;

$\sum(C_L \times V_{\text{CC}}^2 \times f_o)$ = sum of outputs.

Table 10: Dynamic characteristics type 74HCT244

$GND = 0\text{ V}$; $t_r = t_f = 6\text{ ns}$; $C_L = 50\text{ pF}$ unless otherwise specified; for test circuit see [Figure 8](#).

Symbol	Parameter	Conditions	Min	Typ	Max	Unit
$T_{\text{amb}} = 25\text{ °C}$						
t_{PHL} , t_{PLH}	propagation delay nAn to nYn	see Figure 6				
		$V_{\text{CC}} = 4.5\text{ V}$	-	13	22	ns
		$V_{\text{CC}} = 5\text{ V}$; $C_L = 15\text{ pF}$	-	11	-	ns
t_{PZH} , t_{PZL}	3-state output enable time n $\overline{\text{OE}}$ to nYn	$V_{\text{CC}} = 4.5\text{ V}$; see Figure 7	-	15	30	ns
t_{PHZ} , t_{PLZ}	3-state output disable time n $\overline{\text{OE}}$ to nYn	$V_{\text{CC}} = 4.5\text{ V}$; see Figure 7	-	15	25	ns
t_{THL} , t_{TLH}	output transition time	$V_{\text{CC}} = 4.5\text{ V}$; see Figure 6	-	5	12	ns
C_{PD}	power dissipation capacitance	$V_I = GND$ to $(V_{\text{CC}} - 1.5\text{ V})$	[1] -	35	-	pF

Table 10: Dynamic characteristics type 74HCT244 ...continued

$GND = 0\text{ V}$; $t_r = t_f = 6\text{ ns}$; $C_L = 50\text{ pF}$ unless otherwise specified; for test circuit see [Figure 8](#).

Symbol	Parameter	Conditions	Min	Typ	Max	Unit
$T_{amb} = -40\text{ °C to }+85\text{ °C}$						
t_{PHL} , t_{PLH}	propagation delay nAn to nYn	$V_{CC} = 4.5\text{ V}$; see Figure 6	-	-	28	ns
t_{PZH} , t_{PZL}	3-state output enable time nOE to nYn	$V_{CC} = 4.5\text{ V}$; see Figure 7	-	-	38	ns
t_{PHZ} , t_{PLZ}	3-state output disable time nOE to nYn	$V_{CC} = 4.5\text{ V}$; see Figure 7	-	-	31	ns
t_{THL} , t_{TLH}	output transition time	$V_{CC} = 4.5\text{ V}$; see Figure 6	-	-	15	ns
$T_{amb} = -40\text{ °C to }+125\text{ °C}$						
t_{PHL} , t_{PLH}	propagation delay nAn to nYn	$V_{CC} = 4.5\text{ V}$; see Figure 6	-	-	33	ns
t_{PZH} , t_{PZL}	3-state output enable time nOE to nYn	$V_{CC} = 4.5\text{ V}$; see Figure 7	-	-	45	ns
t_{PHZ} , t_{PLZ}	3-state output disable time nOE to nYn	$V_{CC} = 4.5\text{ V}$; see Figure 7	-	-	38	ns
t_{THL} , t_{TLH}	output transition time	$V_{CC} = 4.5\text{ V}$; see Figure 6	-	-	18	ns

[1] C_{PD} is used to determine the dynamic power dissipation (P_D in μW):

$$P_D = C_{PD} \times V_{CC}^2 \times f_i \times N + \sum(C_L \times V_{CC}^2 \times f_o) \text{ where:}$$

f_i = input frequency in MHz;

f_o = output frequency in MHz;

C_L = output load capacitance in pF;

V_{CC} = supply voltage in V;

N = number of inputs switching;

$\sum(C_L \times V_{CC}^2 \times f_o)$ = sum of outputs.

12. Waveforms

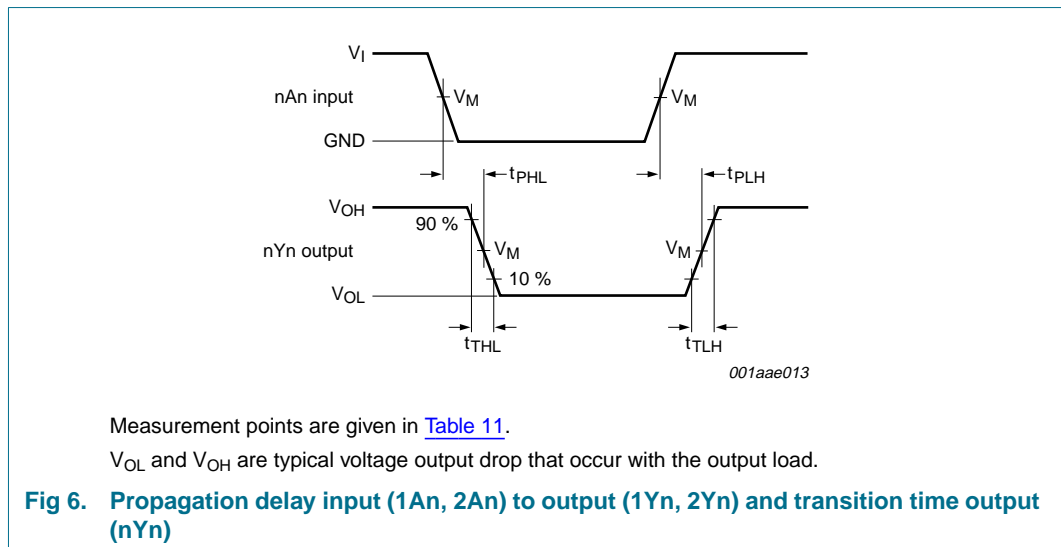

13. Package outline

DIP20: plastic dual in-line package; 20 leads (300 mil)

SOT146-1

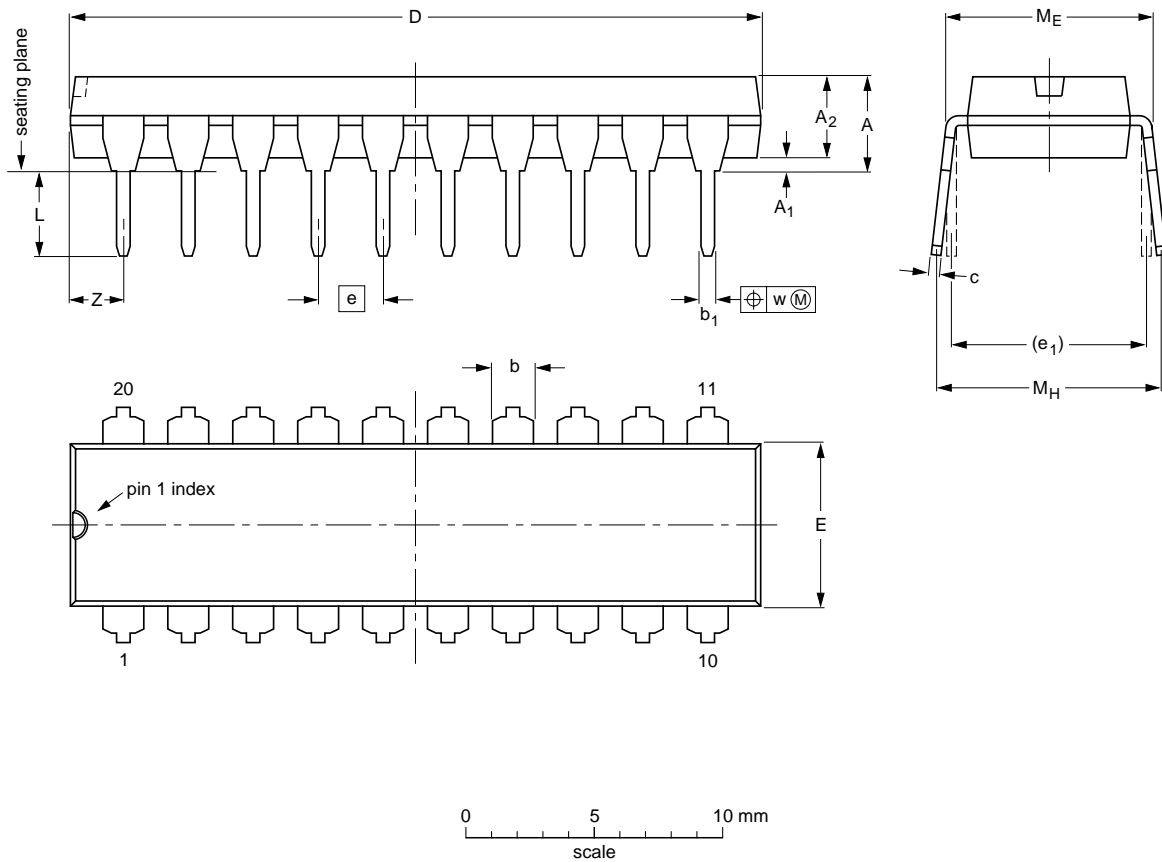

DIMENSIONS (inch dimensions are derived from the original mm dimensions)

UNIT	A max.	A ₁ min.	A ₂ max.	b	b ₁	c	D ⁽¹⁾	E ⁽¹⁾	e	e ₁	L	M _E	M _H	w	Z ⁽¹⁾ max.
mm	4.2	0.51	3.2	1.73 1.30	0.53 0.38	0.36 0.23	26.92 26.54	6.40 6.22	2.54	7.62	3.60 3.05	8.25 7.80	10.0 8.3	0.254	2
inches	0.17	0.02	0.13	0.068 0.051	0.021 0.015	0.014 0.009	1.060 1.045	0.25 0.24	0.1	0.3	0.14 0.12	0.32 0.31	0.39 0.33	0.01	0.078

Note

1. Plastic or metal protrusions of 0.25 mm (0.01 inch) maximum per side are not included.

OUTLINE VERSION	REFERENCES				EUROPEAN PROJECTION
	IEC	JEDEC	JEITA		
SOT146-1		MS-001	SC-603		

Fig 9. Package outline SOT146-1 (DIP20)